



"Life Ko Kare Lift"
DOLPHIN VLIFT

**COMPLETE ELEVATOR
SOLUTIONS** Toll Free No: 1800 5722 876

PASSENGER | HOME | GOODS
AUTOMOBILE | PERSONAL
PLATFORM ELEVATORS

"Life Ko Kare Lift"
DOLPHIN VLIFT

TYPES OF ELEVATORS



Passenger Elevators - Low rise

Max Capacity - 26 Passenger
Max Travel - 20 mtr
Max Speed - 0.7 mps



Passenger Elevators - Mid Rise

Max Capacity - 26 Passenger
Max Travel - 30 mtr
Max Speed - 1 mps



Passenger Elevators - High Rise

Max Capacity - 26 Passenger
Max Travel - 66 mtr
Max Speed - 1.5 / 1.75 mps



Passenger Elevators - Belt Drive

Max Capacity - 13 Passenger
Max Travel - 30 mtr
Max Speed - 1 mps



Hospital Elevators

Max Capacity - 26 Passenger
Max Travel - 30 mtr
Max Speed - 1 mps



Home/ Villa Elevators

Max Capacity - 8 Passenger
Max Travel - 12 mtr
Max Speed - 1 mps



Goods/ Freight Elevators

Max Capacity - 5000 kgs

Max Travel - 21 mtr

Max Speed - 1 mps



Automobile Lift

Max Capacity - 4000 kgs

Max Travel - 21 mtr

Max Speed - 1 mps



Dumb Waiter

Max Capacity - 250 kgs

Max Travel - 30 mtr

Max Speed - 0.5 mps



Personal Shaftless

Max Capacity - 272 kgs

Max Travel - 3 mtr

Max Speed - 0.3 mps



Platform Elevators

Max Capacity - 500 kgs

Max Travel - 6 mtr

Max Speed - 0.5 mps



Customised Shafts

Max Capacity - 8 Passenger

Max Travel - 12 mtr

Max Speed - 0.5 mps

PASSENGER ELEVATORS



**DOLPHIN
VLIFT**

**"Life Ko Kare Lift"
DOLPHIN VLIFT**

Passenger elevators are manufactured with load capacity of 272, 340, 408, 544, 680, 884, 1068, 1360 kg upto 1768 kg and speed movement up to 2 m/sec.

They are designed with the upper and the lower machine room for an installation in the dwelling houses, administrative and residential buildings, hotels, banks and offices.

The elevators described are featured by:

- smooth run and improved accuracy of - stop
- comfortable cabin and reduced noise level
- vandalism-proof control panels and calling posts with illumination
- indicators of the movement direction and cabin position
- microprocessor-based control station;
- frequency regulator of the motor and door drive speed
- LED lighting;
- indication of the cabin overload

Complete Elevator Solutions

Toll Free No: 1800 5722 876

**"Life Ko Kare Lift"
DOLPHIN VLIFT**

World class machines

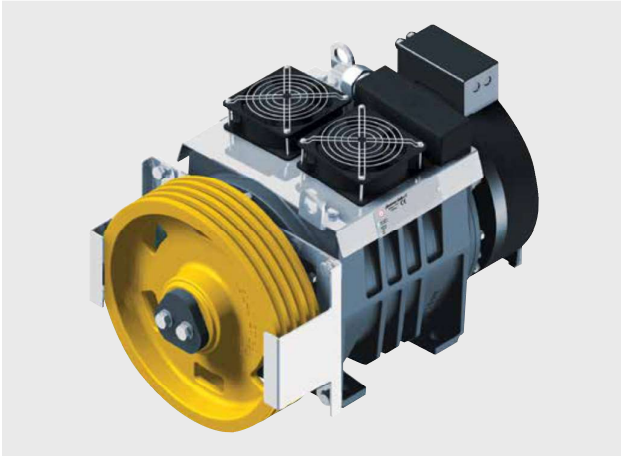

Mechanical excellence

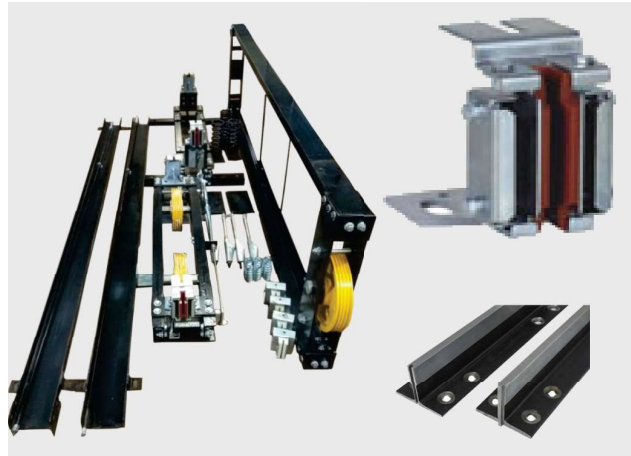

Branded doors

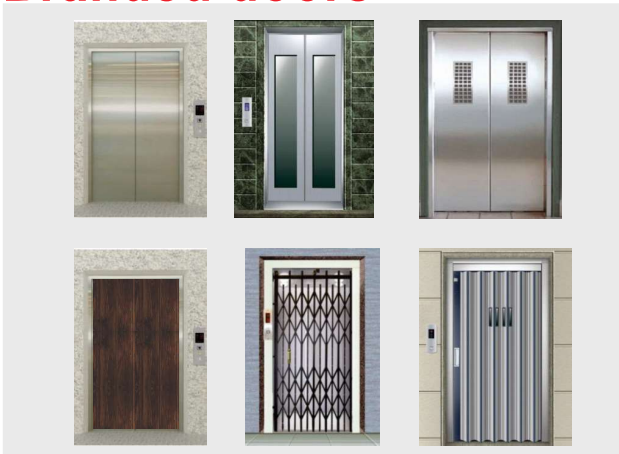

Integrated drives



Top safety features



Future proof

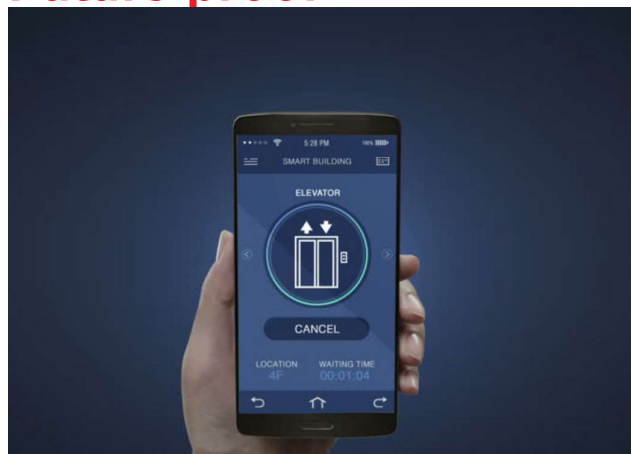

BELT DRIVE PASSENGER

2:1 MRL TRACTION GEARLESS

AUTO DOORS



**DOLPHIN
VLIFT**



TECHNICAL SPECIFICATIONS

Max Capacity	13 Passenger
Max Speed	1 mps
Max Travel	30 Mtr
Roping	2:1
Min Pit	1500mm
Min Overhead	4250mm

"Life Ko Kare Lift"
DOLPHIN VLIFT



KEY FEATURES



DOOR SENSOR



INTEGRATED DRIVE



VOICE ANNOUNCER



100% SAFETY
FEATURES



1 MILLION
BUTTON TEST



FIREMAN SWITCH



EMERGENCY ALARM



CLOSE LOOP
SYSTEM



OVERLOAD SENSOR

Belt Drive Elevator Solutions

**DOLPHIN
VLIFT**



Shaft Spacing Saving

**A Small Machine Means Direct Shaft Saving and
More Area for the Passenger and Cabin**



Compact Machine Design

**The Lower Bend Radius required for Coated
Flat Steel Belts means A Small Compact Machine
And More Efficient than Geared Systems**

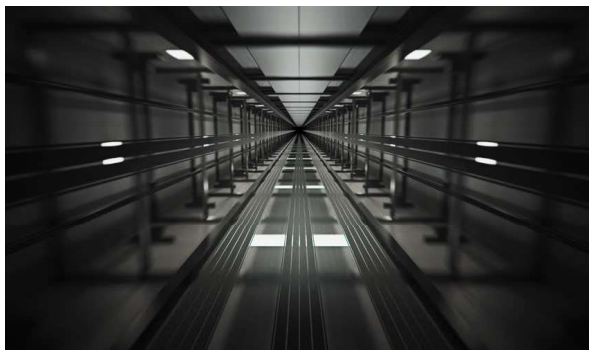

Smooth Travel

**Conventional Ropes replaced for Coated Flat
Steel Belts Eliminating Noise created by Metal
To Metal noise made by Conventional Systems**

"Life Ko Kare Lift"
DOLPHIN VLIFT

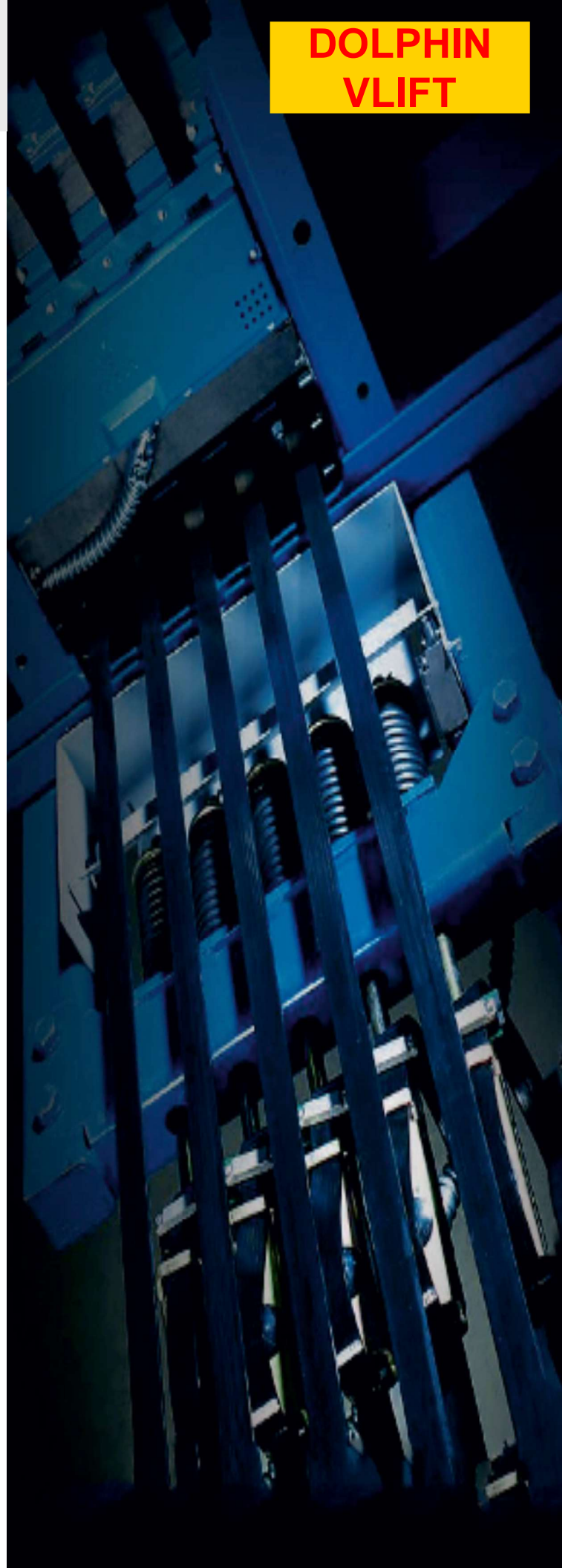

DOLPHIN VLIFT

BOTTOM PULLEY ARRANGEMENT

BELT DRIVE

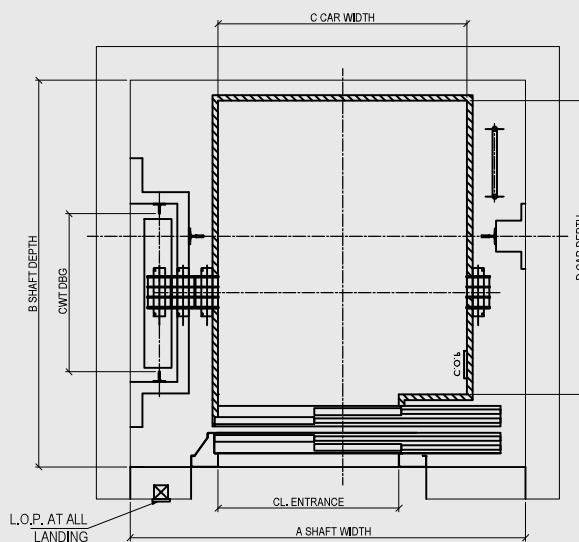
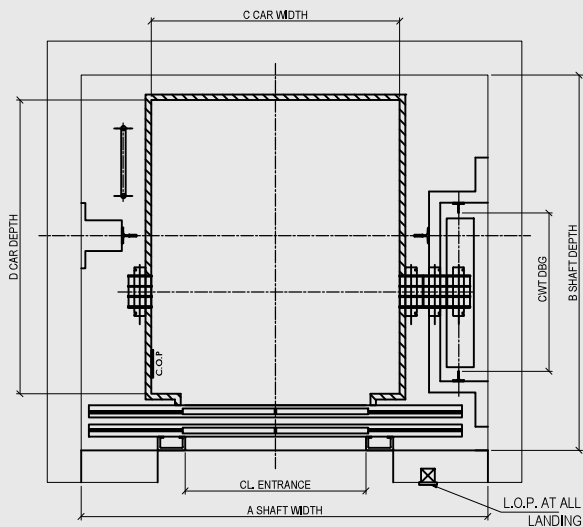
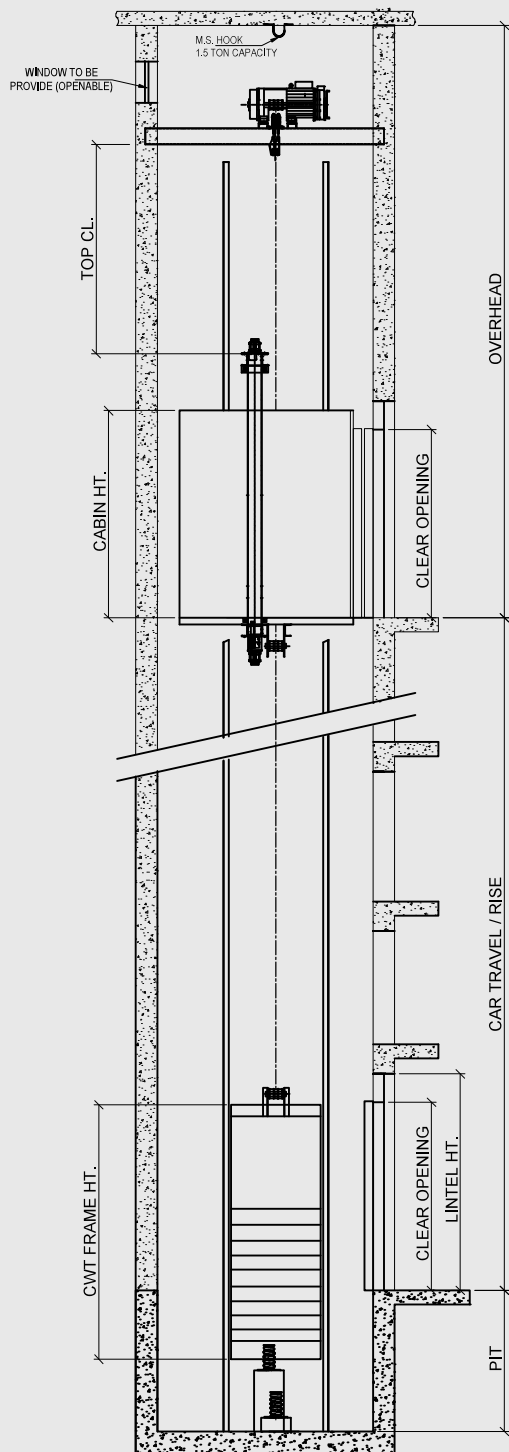

PASSENGER TRACTION AUTO BELT DRIVE MRL 2:1

PASSENGER	LOAD KG.	ENTRANCE	LIFT WELL C.O.				CAR SIZE C.O.				LIFT WELL TEL.O.	CAR SIZE TEL.O.	SPEED MPS	TRAVEL HT. MTR.	PIT	OVERHEAD
			A	B	C	D	A	B	C	D						
8	544	800x2000	1800	1600	1100	1300	1700	1650	1100	1300	1.0	UP TO 30	1500	4250		
10	680	800x2000	1850	1700	1200	1400	1800	1750	1200	1400	1.0	UP TO 30	1500	4250		
13	884	900x2000	2000	2000	1300	1700	1950	2050	1300	1700	1.0	UP TO 30	1500	4250		

2:1 MRL **AUTO**
TRACTION **BELTDRIVE**

Toll Free No: 1800 5722 876

"Life Ko Kare Lift"
DOLPHIN VLIFT

DOLPHIN VLIFT

CANTILEVER ARRANGEMENT

BELT DRIVE

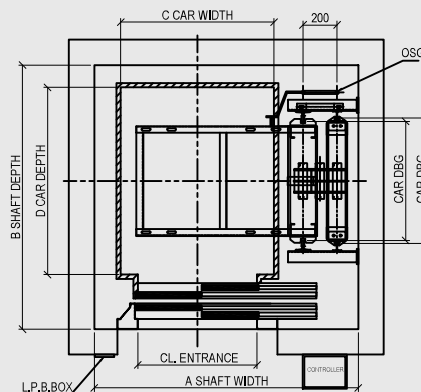
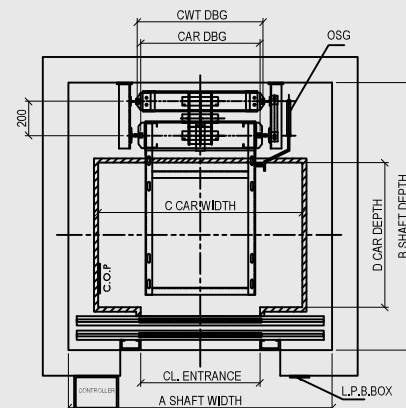
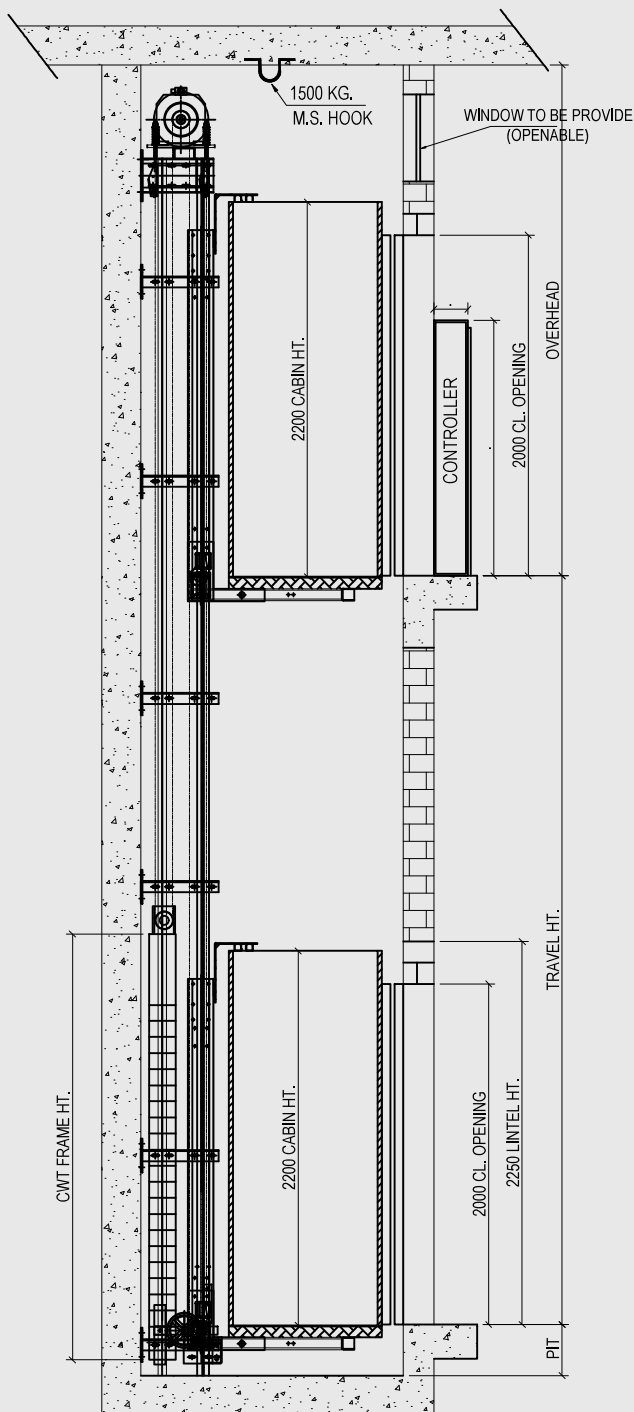

PASSENGER TRACTION CANTILEVER BELT DRIVE MRL 2:1

PASSENGER	LOAD KG.	ENTRANCE	LIFT WELL C.O.				CAR SIZE C.O.				LIFT WELL TEL.O.	CAR SIZE TEL.O.	SPEED MPS	TRAVEL HT. MTR.	PIT	OVERHEAD
			A	B	C	D	A	B	C	D						
4	272	700x2000	1550	1350	1100	700	1400	1350	750	1000	0.32-0.63	UP TO 12	300 - 1000	3000 - 4000		
5	340	700x2000	1550	1500	1100	850	1500	1350	900	1000	0.32-0.63	UP TO 12	300 - 1000	3000 - 4000		
6	408	700x2000	1550	1600	1250	900	1600	1450	1000	1100	0.32-0.63	UP TO 12	300 - 1000	3000 - 4000		
8	544	800x2000	1750	1800	1300	1100	1750	1650	1100	1300	0.32-0.63	UP TO 12	300 - 1000	3000 - 4000		

ENGINEERS TO
ELEVATOR INDUSTRY

Toll Free No: 1800 5722 876

DOLPHIN
VLIFT

HOME/VILLA ELEVATOR

2:1 MRL CANTILEVER GEARLESS AUTO/MANUAL DOORS

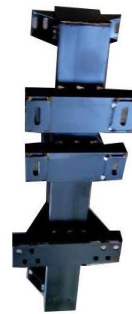

**DOLPHIN
VLIFT**

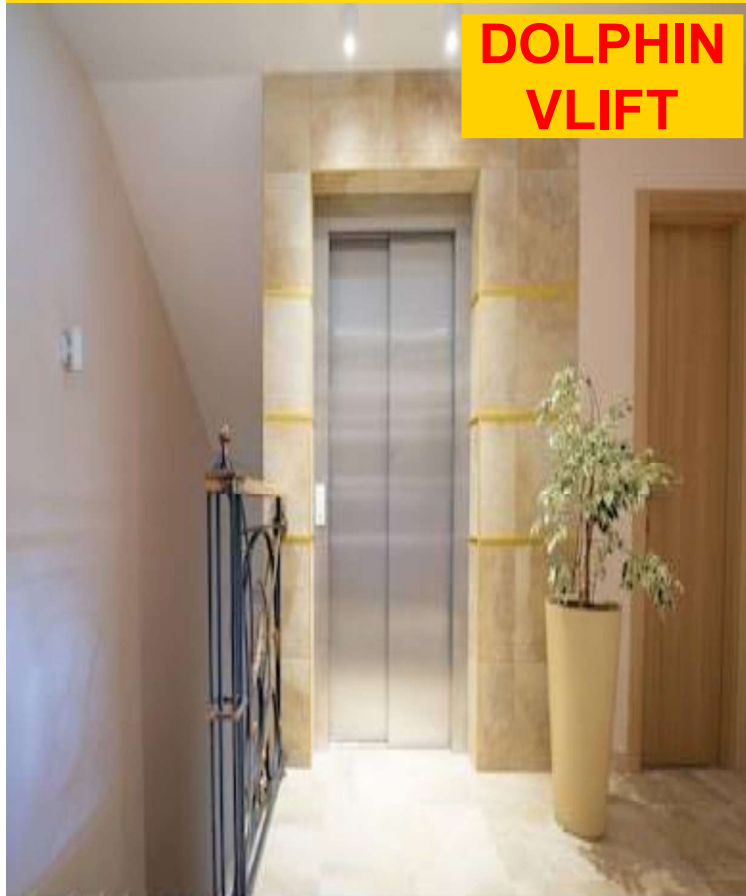

TECHNICAL SPECIFICATIONS

Max Capacity	8 Passenger
Max Speed	1 mps
Max Travel	12 Mtr
Roping	2:1
Min Pit	300mm
Min Overhead	3000mm

"Life Ko Kare Lift"
DOLPHIN VLIFT



KEY FEATURES



SAFE DOOR
OPERATION



INTEGRATED DRIVE



VOICE ANNOUNCER



100% SAFETY
FEATURES



1 MILLION
BUTTON TEST



SMOOTH RIDE



SOS
EMERGENCY ALARM



ENERGY EFFICIENT



OVERLOAD SENSOR

MRL Cantilever Elevator Solutions



Shaft Space Saving

The cantilever design and 200 dia machine extracts maximum space in the shaft for the cabin and passenger.



No Pit and No Overhead

This job can be fit wit 100 Pit and Overhead
Of only 2500mm



Versatile Door Opening Options

The Cantilever Design Model Allows Opposite Side,
90 Degree or Multiple Door and Glass Fittings

"Life Ko Kare Lift"
DOLPHIN VLIFT



**DOLPHIN
VLIFT**

CANTILEVER ARRANGEMENT

AUTO DOORS

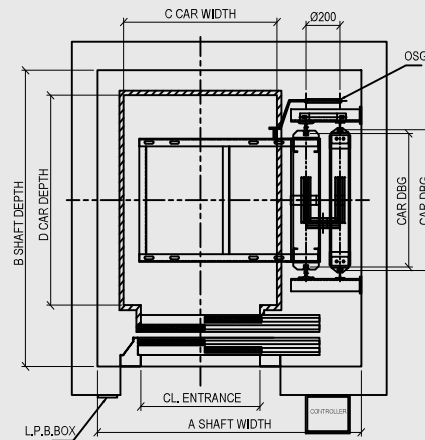
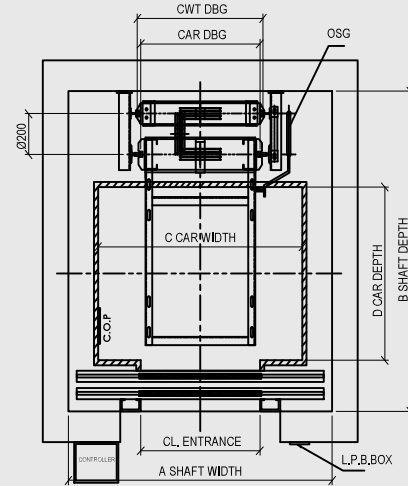
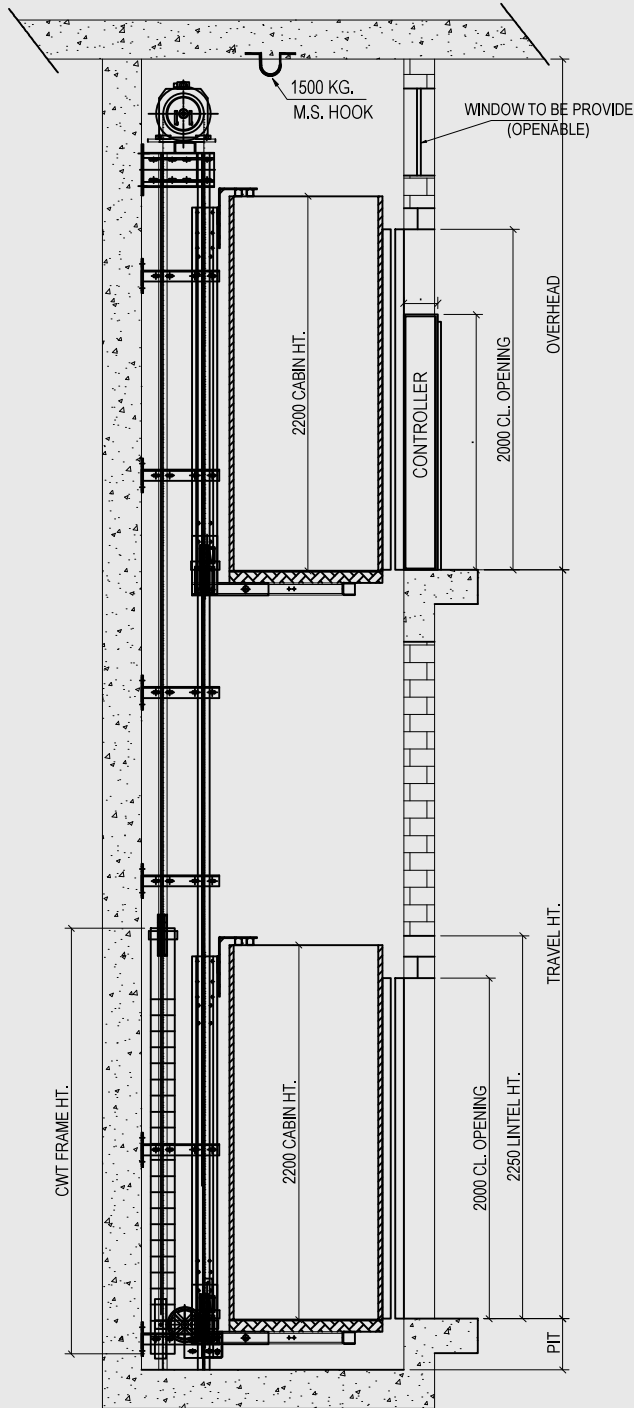

PASSENGER TRACTION CANTILEVER MRL 2:1

PASSENGER	LOAD KG.	ENTRANCE	LIFT WELL C.O.		CAR SIZE C.O.		LIFT WELL TEL.O.		CAR SIZE TEL.O.		SPEED MPS	TRAVEL HT. MTR.	PIT	OVERHEAD
			A	B	C	D	A	B	C	D				
4	272	700x2000	1550	1350	1100	700	1400	1350	750	1000	0.4 - 1.0	UP TO 12	300 - 1500	3000 - 4000
5	340	700x2000	1550	1500	1100	850	1500	1350	900	1000	0.4 - 1.0	UP TO 12	300 - 1500	3000 - 4000
6	408	700x2000	1550	1600	1250	900	1600	1450	1000	1100	0.4 - 1.0	UP TO 12	300 - 1500	3000 - 4000
7	476	800x2000	1750	1650	1300	950	1750	1500	1100	1150	0.4 - 1.0	UP TO 12	300 - 1500	3000 - 4000
8	544	800x2000	1750	1800	1300	1100	1750	1650	1100	1300	0.4 - 1.0	UP TO 12	300 - 1500	3000 - 4000

DOLPHIN VLIFT

CANTILEVER ARRANGEMENT

MANUAL

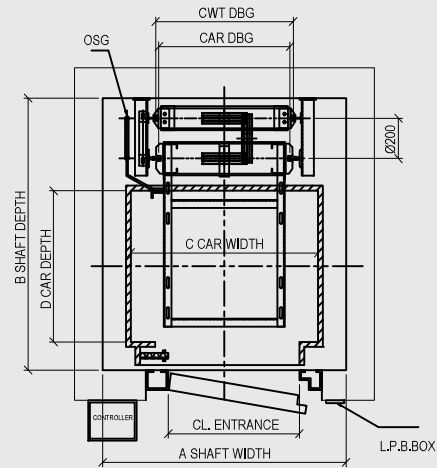
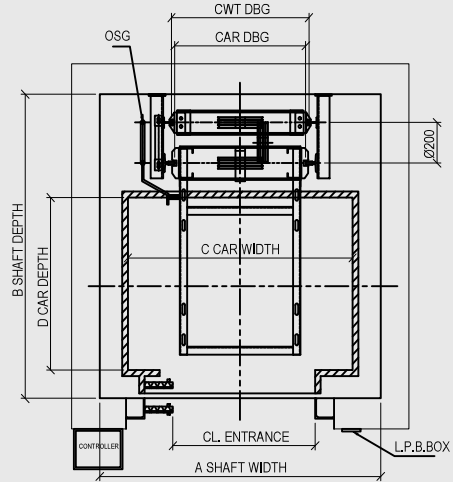
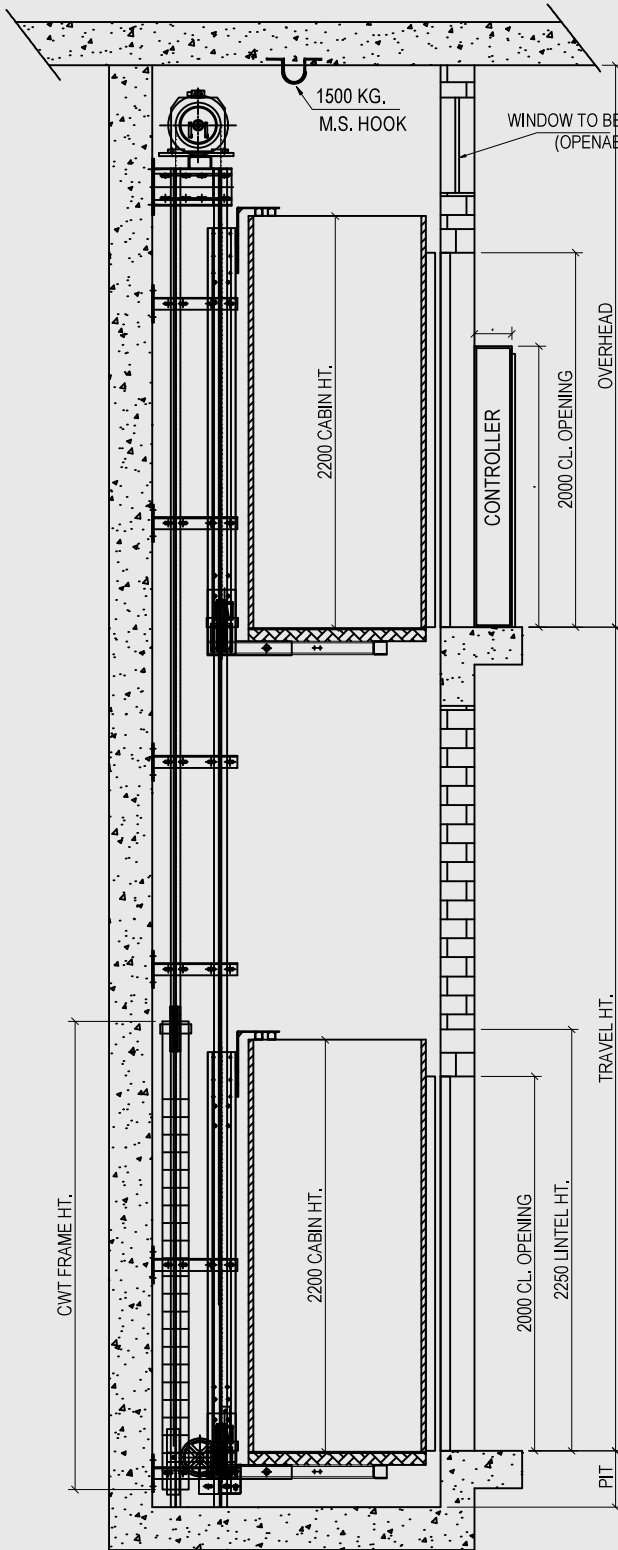

PASSENGER TRACTION CANTILEVER MANUAL MRL 2:1

PASSENGER	LOAD KG.	ENTRANCE	LIFT WELL COLL. O. & SWING O.		CAR SIZE		SPEED MPS	TRAVEL HT. MTR.	PIT	OVERHEAD
			A	B	C	D				
4	272	700x2000	1200	1350	1000	750	0.4 - 1.0	UP TO 12	300 - 1500	3000 - 4000
5	340	700x2000	1200	1500	1050	900	0.4 - 1.0	UP TO 12	300 - 1500	3000 - 4000
6	408	700x2000	1400	1500	1200	900	0.4 - 1.0	UP TO 12	300 - 1500	3000 - 4000
7	476	800x2000	1500	1600	1300	950	0.4 - 1.0	UP TO 12	300 - 1500	3000 - 4000
8	544	800x2000	1500	1750	1300	1100	0.4 - 1.0	UP TO 12	300 - 1500	3000 - 4000

HOME/VILLA ELEVATOR

1:2 MRL CANTILEVER HYDRAULIC AUTO/MANUAL DOORS

**DOLPHIN
VLIFT**

"Life Ko Kare Lift"
DOLPHIN VLIFT



TECHNICAL SPECIFICATIONS

Max Capacity	8 Passenger
Max Speed	0.5 mps
Max Travel	12 Mtr
Roping	1:2
Min Pit	300mm
Min Overhead	2700mm

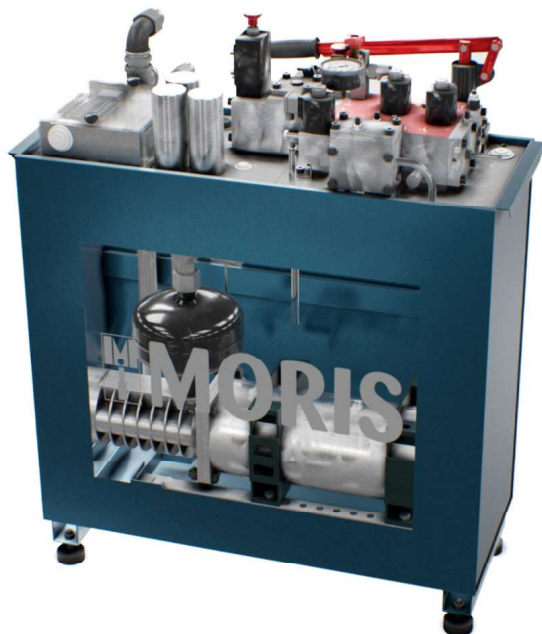

KEY FEATURES



SAFE DOOR OPERATION



INTEGRATED DRIVE



VOICE ANNOUNCER



100% SAFETY FEATURES



1 MILLION BUTTON TEST



SMOOTH RIDE



EMERGENCY ALARM



ENERGY EFFICIENT



OVERLOAD SENSOR

Hydraulic Cantilever Elevator Solutions



Maximum Space Saving

Hydraulic Systems Fit in a Small Space and allows
Maximum Space for Cabin and Passenger



Top Power Efficiency

Proven to Use Less Energy Than Geared and
Gearless Systems



No Pit and No Overhead

No or very Low Pit Requirement and Ease in
Fitting in the Lowest Overhead Requirements

"Life Ko Kare Lift"
DOLPHIN VLIFT



DOLPHIN VLIFT

CANTILEVER ARRANGEMENT

AUTO DOORS

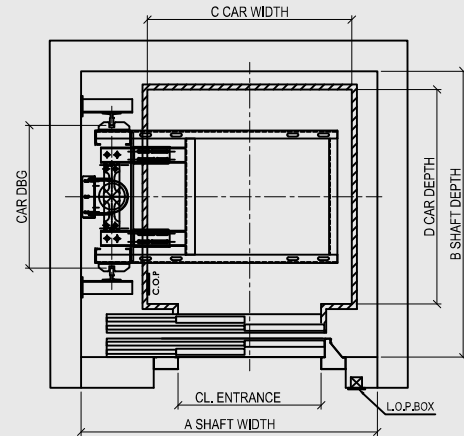
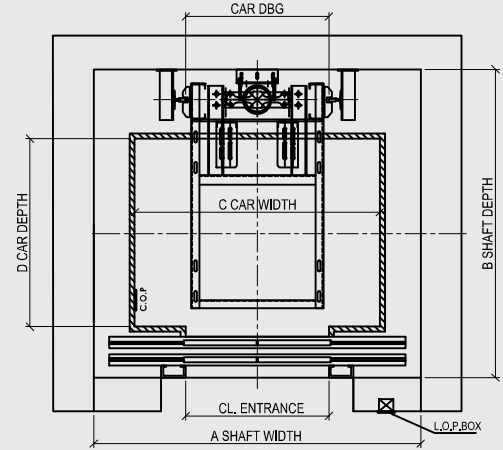
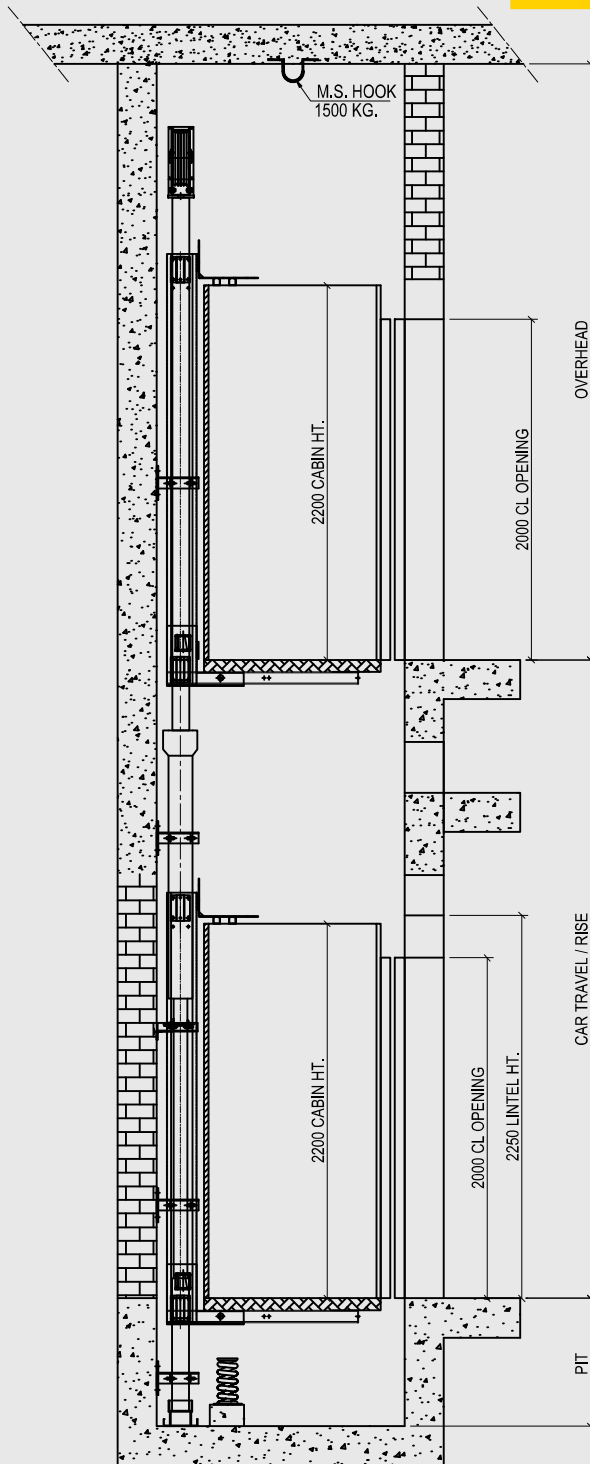

PASSENGER HYDRULIC CANTILEVER 1:2

PASSENGER	LOAD KG.	ENTRANCE	LIFT WELL C.O.				CAR SIZE C.O.				LIFT WELL TEL.O.	CAR SIZE TEL.O.	SPEED MPS	TRAVEL HT. MTR.	PIT	OVERHEAD
			A	B	C	D	A	B	C	D						
4	272	700x2000	1550	1225	1100	700	1250	1250	850	900	0.3 - 0.5	UP TO 12	300 - 1500	2700 - 3500		
5	340	700x2000	1550	1375	1100	850	1350	1350	950	1000	0.3 - 0.5	UP TO 12	300 - 1500	2700 - 3500		
6	408	700x2000	1550	1425	1200	900	1400	1450	1000	1100	0.3 - 0.5	UP TO 12	300 - 1500	2700 - 3500		
8	544	800x2000	1750	1625	1300	1100	1500	1650	1100	1300	0.3 - 0.5	UP TO 12	300 - 1500	2700 - 3500		

1:2 **AUTO**
INDIRECT HYDRAULIC

Toll Free No: 1800 5722 876

"Life Ko Kare Lift"
DOLPHIN VLIFT

DOLPHIN VLIFT

CANTILEVER ARRANGEMENT

MANUAL

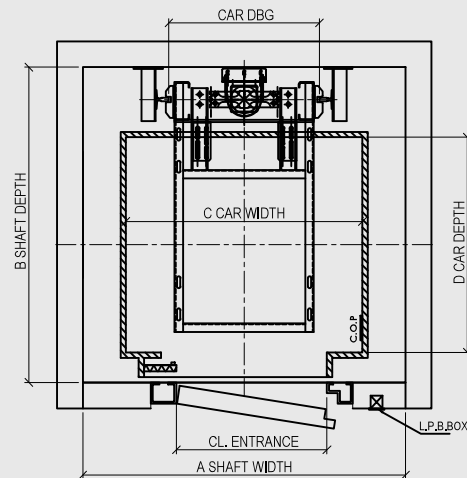
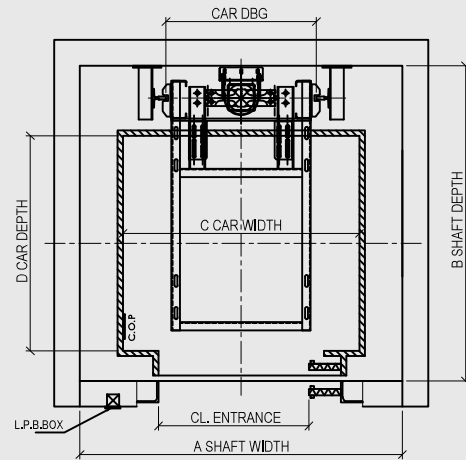
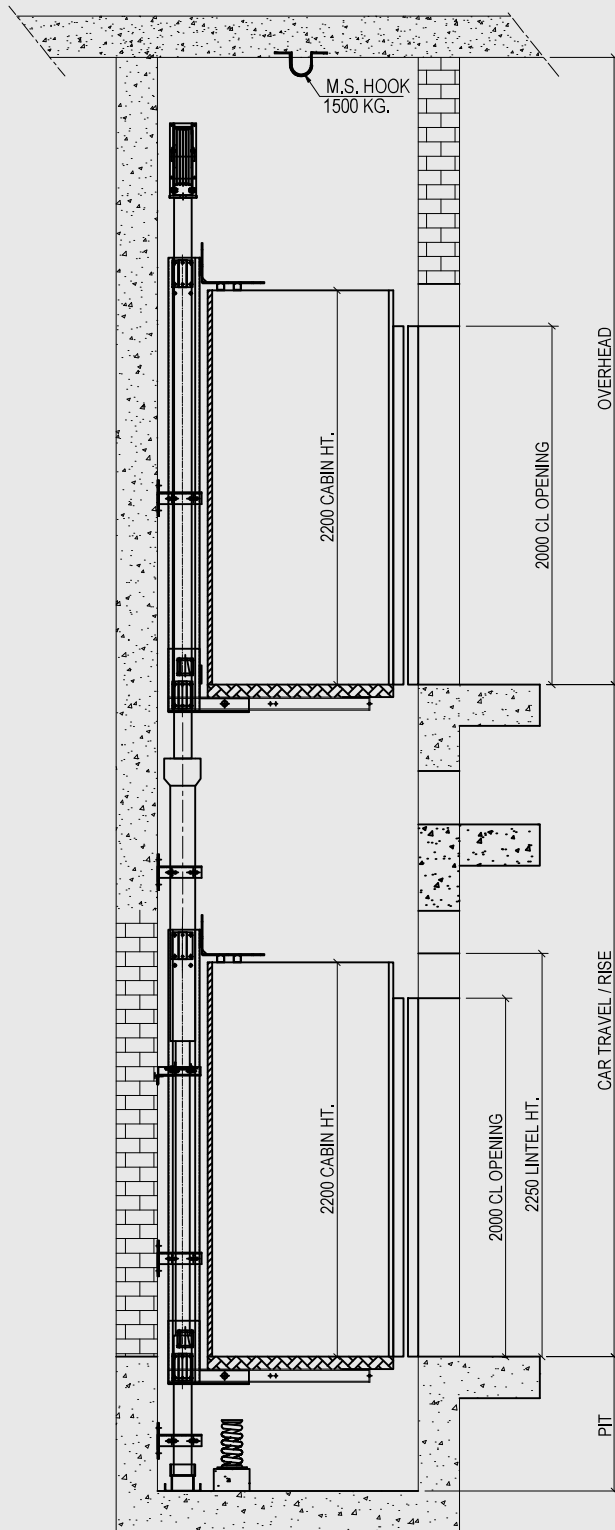

PASSENGER HYDRULIC CANTILEVER 1:2

PASSENGER	LOAD KG.	ENTRANCE	LIFT WELL COLL. O. & SWING O.		CAR SIZE		SPEED MPS	TRAVEL HT. MTR.	PIT	OVERHEAD
			A	B	C	D				
4	272	700x2000	1150	1225	1000	750	0.3 - 0.5	UP TO 12	300 - 1500	2700 - 3500
5	340	700x2000	1200	1375	1050	900	0.3 - 0.5	UP TO 12	300 - 1500	2700 - 3500
6	408	700x2000	1350	1375	1200	900	0.3 - 0.5	UP TO 12	300 - 1500	2700 - 3500
8	544	800x2000	1450	1575	1300	1100	0.3 - 0.5	UP TO 12	300 - 1500	2700 - 3500

**1:2 MANUAL
INDIRECT HYDRULIC**

Toll Free No: 1800 5722 876

**DOLPHIN
VLIFT**

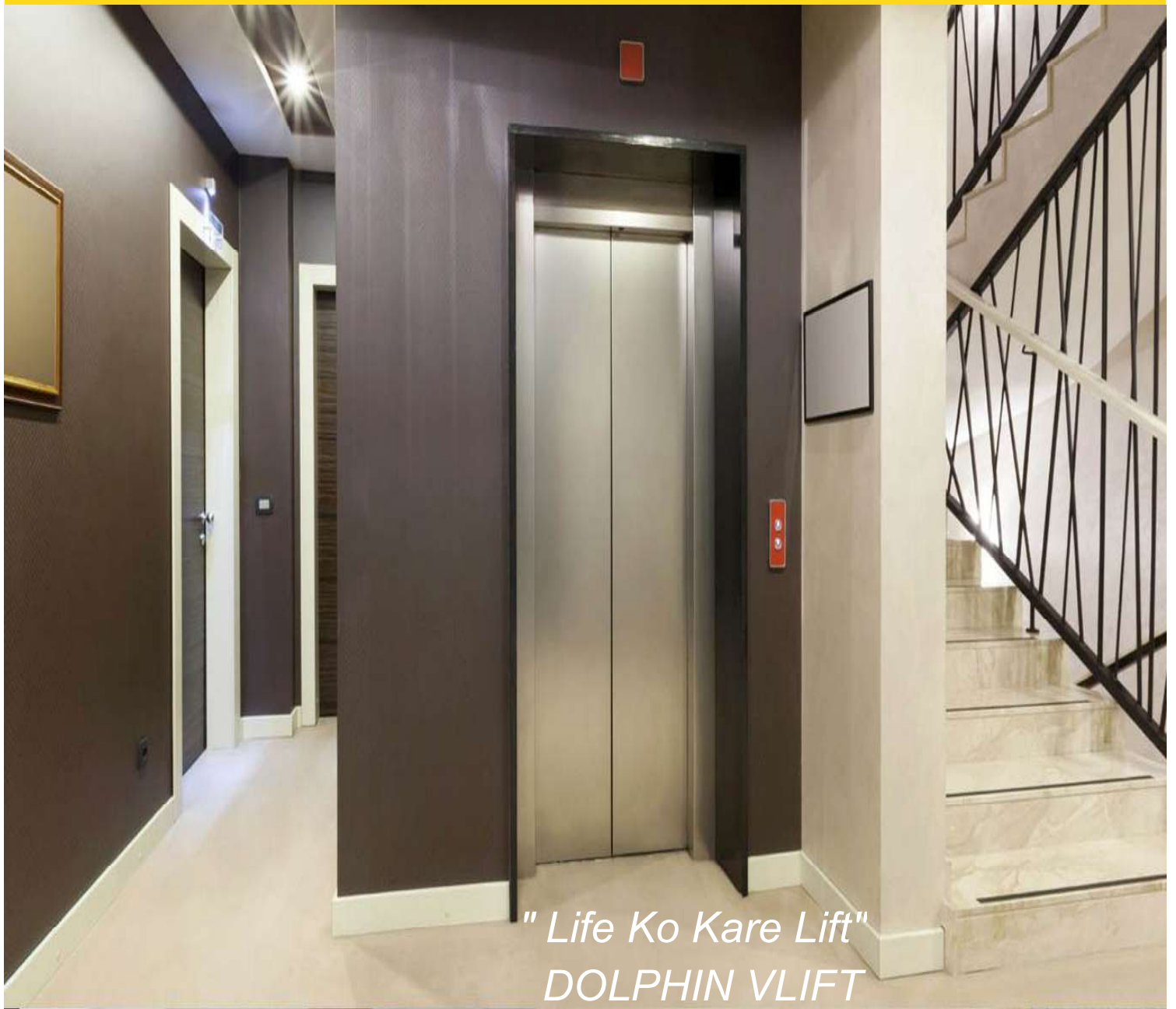

"Life Ko Kare Lift"
DOLPHIN VLIFT

**VLIFT TECHNOLOGIES PVT LTD
INDIA.
Toll Free No: 1800 5722 876**

**+91 9948797917
+91 9849511198**

"Life Ko Kare Lift"
DOLPHIN VLIFT

**ENGINEERS TO
ELEVATOR INDUSTRY**